

**United States Court of Appeals
for the Federal Circuit**

PHIL-INSUL CORP., DBA INTEGRASPEC,
Plaintiff-Appellant

v.

AIRLITE PLASTICS CO., FORMTECH, LLC,
Defendants-Appellees

2016-1982

Appeal from the United States District Court for the District of Nebraska in No. 8:12-cv-00151-JFB-TDT, Chief Judge Joseph F. Bataillon.

Decided: April 17, 2017

PAUL ADAMS, The Adams Law Firm, Albuquerque, NM, argued for plaintiff-appellant.

LOUIS DISANTO, Banner & Witcoff, Ltd., Chicago, IL, argued for defendants-appellees. Also represented by JON O. NELSON.

Before O'MALLEY, BRYSON, and WALLACH, *Circuit Judges*.
O'MALLEY, *Circuit Judge*.

Phil-Insul Corp. d/b/a IntegraSpec (“IntegraSpec”) filed suit against Airlite Plastics Co. and Formtech, LLC (collectively, “Airlite”) alleging infringement of U.S. Patent No. 5,428,933 (“the ’933 Patent”), which relates to insulating concrete forms (“ICFs”) that are used in the construction of buildings. Airlite moved for summary judgment of noninfringement, arguing that IntegraSpec’s claims are precluded by our decision in a prior action. In that case, IntegraSpec asserted claims from the same patent against different defendants with similar products. There, after construing the claims, the district court granted summary judgment of noninfringement, and subsequently granted the parties’ stipulated request for a Rule 54(b) certification for immediate appeal. IntegraSpec timely appealed, challenging only the district court’s claim construction. We summarily affirmed the district court’s final judgment without an opinion. *Phil-Insul Corp. v. Reward Wall Sys., Inc.*, 580 F. App’x 907 (Fed. Cir. 2014).

In this case, Airlite argued that IntegraSpec’s infringement claims are the same as the infringement claims it asserted and lost in *Reward Wall* and that Airlite’s accused products have the same design as the products found noninfringing in that prior litigation. The district court agreed, and granted Airlite’s motion for summary judgment of noninfringement. *Phil-Insul Corp. v. Airlite Plastics, Co.*, No. 8:12-cv-151, 2016 WL 5107131 (D. Neb. Mar. 2, 2016) (“*Decision on Appeal*”). Because we agree that IntegraSpec’s claims are barred by collateral estoppel, we affirm.

I. BACKGROUND

A. The ’933 Patent

IntegraSpec is the assignee of record for the ’933 Patent, which originally issued on July 4, 1995. The ’933 Patent underwent two ex parte reexaminations before the United States Patent & Trademark Office (“PTO”): one

that concluded on September 21, 2010, and another that concluded on July 14, 2014.

The '933 Patent is directed to ICFs, which are expanded polystyrene foam blocks used as molds to cast concrete walls. The ICFs are stacked to form a hollow wall which is then filled with concrete. The ICFs remain in place after the concrete sets to serve as insulation for the building. The ICFs consist of two parallel foam panels that form sidewalls. The top and bottom edges of the sidewalls have interconnecting means used to connect one ICF to another when they are stacked.

Figure 1, shown below, illustrates a preferred embodiment of an ICF having interconnecting means (16) that include two rows of projections (18) and recesses (20) on the top and the bottom edges of each panel/sidewall (10 & 12):

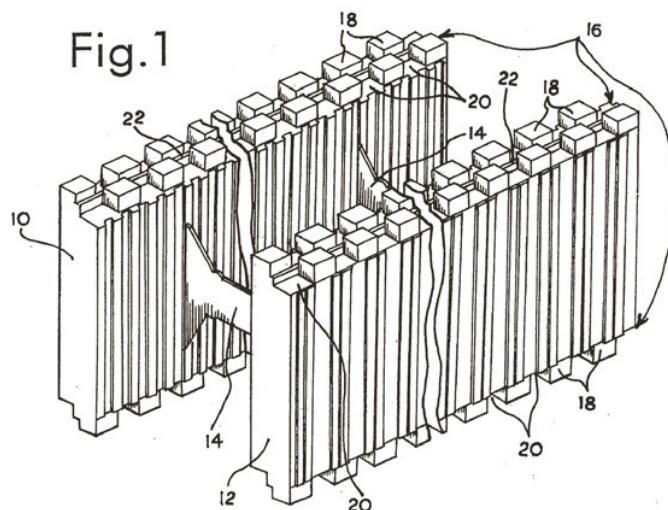

The specification explains that, unlike prior art ICFs, which had to be arranged in a specific way for interconnection, the claimed ICFs are designed to permit interconnection “with like blocks or panels in a bi-directional and/or reversible manner.” ’933 Patent, col. 1, ll. 8-13.

Because the claimed ICFs can be stacked in a number of ways, they are “easier to interconnect” and installation can proceed at a faster pace and with less waste because the bidirectional and reversible design avoids orientation restrictions. *Id.* at col. 1, ll. 38-48.

As originally issued, claim 1 was directed to ICFs where the interconnecting means on the top and bottom edges of each panel “comprise[d] at least two rows of alternating projections and recesses . . . wherein said recess of one row is adjacent said projection of the other row.” ’933 Patent, col. 6, ll. 11-15. Claim 2, as originally issued, claimed “[a]n insulating construction member according to claim 1, wherein said member is an insulating construction block.” *Id.* at col. 6, ll. 23-25.

After the first reexamination, Claim 1 provided as follows:

In a bi-directional and reversible insulating construction member having substantially planar ends and top and bottom edges and interconnecting means on said top and on said bottom edges, the improvement wherein each said top interconnecting means and each said bottom interconnecting means has a pattern, each pattern comprising *at least two longitudinally extending rows* of alternating, continuous, immediately adjacent projections and recesses, extending continuously along the entire length of said top and bottom edges, the end projection in one row flush with at least a portion of one of said end planes, within each said pattern each of said projections and recesses in each one of said at least two rows within said pattern being of *substantially the same dimension*, wherein within each said pattern said recess of one row is *adjacent* said projection of the other row, and wherein said interconnecting means patterns on said top and bottom edges are

the same and are offset arranged such that said recess of one row in said pattern on said top edge is opposed to said projection of an opposite row in said pattern on said bottom edge; whereby said insulating construction member can be interconnected with a like member in a bi-directional and reversible manner.

Ex Parte Reexamination Certificate for U.S. Patent No. 5,428,933 issued Sept. 21, 2010 (“First Reexam Cert.”) at col. 1, ll. 26-47 (emphases added).

Claim 2 was amended as follows:

An insulating construction member according to claim 1, wherein said member is an insulating construction block comprising two panels, each of said panels having a pattern on the top and bottom edges, each of said patterns on each of said panels comprising *at least one longitudinally extending row* of alternating, continuous, immediately adjacent projections and recesses and each of said projections and each of said recesses within each said pattern in said at least one row being of substantially the same dimension.

Id. at col. 1, ll. 49-57 (emphasis added).

Independent Claim 19 was added in the first ex parte reexamination. Claim 19 contains the same “adjacent” requirement present in Claim 1.

The PTO issued a second ex parte reexamination certificate in 2014. As a result of that reexamination, claims 1, 3, 6-10, and 24 were cancelled. Ex Parte Reexamination Certificate for U.S. Patent No. 5,428,933 issued Jul. 14, 2014 (“Second Reexam Cert.”) at col. 1. The patentability of claims 2, 4, 5, 11, 13-16, 19-23, and 25-27 was confirmed, however. *Id.*

B. The *Reward Wall* Litigation

In February 2011, IntegraSpec filed suit against multiple defendants—including Reward Wall Systems, Inc. (“Reward Wall”) and Nudura Corporation (“Nudura”)—alleging infringement of the ’933 Patent. The parties filed a joint motion for early claim construction, indicating that two independent claims were at issue—Claim 1 and Claim 19. The parties requested that the district court construe three claim terms found in both claims, two of which are relevant to this appeal: “adjacent” and “substantially the same dimension.” Joint Motion for Early Claim Construction at 2, *Phil-Insul Corp. v. Reward Wall Sys., Inc.*, No. 8:12-cv-91 (D. Neb. Nov. 22, 2011), ECF No. 79. The parties agreed that these limitations should be construed the same way in both claims. *Id.*

The district court conducted a Markman hearing in June 2012, and issued its claim construction order soon thereafter. In relevant part, the court construed the term “adjacent” to mean “next to . . . on the same panel or sidewall.” *Phil-Insul Corp. v. Reward Wall Sys., Inc.*, No. 8:12-cv-91, 2012 WL 2958233, at *7 (D. Neb. July 19, 2012). Looking at the prosecution history, the court found that the patentee added the limitation “at least two rows” in Claim 1 to distinguish it from prior art that disclosed an ICF block with one row of alternating projections and recesses on each sidewall. *Id.* at *9. The court recognized that, although Claim 2 “discloses a construction block on which each panel may have only one row of projections and recesses,” it would be inconsistent with the specification and the prosecution history to construe “adjacent” in Claim 1 to encompass an ICF block having only one row. *Id.* at *9, n.13. The district court construed “substantially the same dimension” to mean “the same measurable length, breadth, area and volume, with only minor variations in dimension of up to about 10%.” *Id.* at *11.

Following the district court's claim construction, the defendants in *Reward Wall* separately moved for summary judgment of noninfringement. The district court issued two decisions finding that the accused products did not infringe the claims of the '933 Patent, either literally or under the doctrine of equivalents.

In the first, the district court addressed whether the accused ICFs contained the "adjacent" limitation. *Phil-Insul Corp. v. Reward Wall Sys., Inc.*, No. 8:12-cv-91, 2012 WL 5906546, *4 (D. Neb. Nov. 26, 2012). With respect to the Nudura ICFs, IntegraSpec did not argue that the products literally infringed, but instead asserted infringement under the doctrine of equivalents. *Id.* at *5 ("IntegraSpec does not contend that the accused Nudura ICFs or the accused Reward Wall ICFs literally infringe the '933 Patent."). Looking to the prosecution history, the court found that there was a narrowing amendment that limited the scope of the patent such that an ICF with less than two rows of alternating projections and recesses on a given panel or sidewall cannot infringe. *Id.* at *6-7. Given this amendment, the court concluded that "prosecution history precludes an ICF with one row of projections and recesses on a panel or sidewall . . . from infringing the '933 Patent under the doctrine of equivalents." *Id.* at *8. Because it was undisputed that the Nudura ICFs had only one row of alternating projections and recesses on a given panel, the court found that the Nudura ICFs did not infringe the asserted claims—which included Claim 2—as a matter of law. *Id.*

In the second decision, the district court addressed whether the accused ICFs contained the "substantially the same dimension" limitation. IntegraSpec conceded that, given the court's construction of this limitation, it could not argue that the accused Reward Wall ICFs literally infringed the '933 Patent. *Phil-Insul Corp. v. Reward Wall Sys., Inc.*, No. 8:12-cv-91, 2013 WL 4774726, *5 (D. Neb. Sept. 5, 2013). Indeed, it was undisputed that

the Reward Wall iForm ICFs included “projections and/or recesses that differ in dimension by at least twice the 10% threshold specified in the court’s construction of the limitation ‘substantially the same dimension.’” *Id.* at *14. As such, the only issue was whether the Reward Wall ICFs infringed under the doctrine of equivalents. Looking to the prosecution history, the court found that, “to gain issuance of the ’933 Patent, [IntegraSpec] limited its claims to ICFs with projections and recesses having ‘the same measurable length, breadth, area, and volume.’” *Id.* at *12. Given this concession, the court found that “IntegraSpec is estopped from asserting that ICFs with a row of projections and recesses that do not each have the same measurable length, breadth, area, and volume contain equivalents of the ‘substantially the same dimension’ limitation.” *Id.* The court concluded, therefore, that the Reward Wall iForm ICFs did not infringe as a matter of law.

Given the district court’s decisions entering summary judgment of noninfringement, the parties stipulated to jointly request certification for immediate appeal under Rule 54(b) of the Federal Rules of Civil Procedure. The court granted the parties’ request and entered final judgment in favor of the defendants.

IntegraSpec appealed the district court’s final judgment to this court, challenging only the court’s construction of the terms “adjacent” and “dimension.” *Decision on Appeal*, 2016 WL 5107131, at *5 (“On appeal, IntegraSpec challenged only the court’s claim construction, specifically, the construction of the terms ‘adjacent’ and ‘dimension.’”). IntegraSpec did not challenge any of the issues determined in the district court’s noninfringement decisions. *Id.*

After briefing on appeal, but before oral argument, the PTO issued the second ex parte reexamination certificate, confirming the patentability of Claims 2, 4, 5, 11, 13-

16, 19-23, and 25-27. *Id.* IntegraSpec filed an unopposed motion requesting that this court take judicial notice of the results of the reexamination proceedings. We granted that motion on September 22, 2014. Order, *Phil-Insul Corp. v. Reward Wall Sys., Inc.*, No. 14-1078 (Fed. Cir. Sept. 22, 2014), ECF No. 65. The court heard oral argument on October 7, 2014, and summarily affirmed the district court's judgment pursuant to Federal Circuit Rule 36. *Phil-Insul Corp. v. Reward Wall Sys., Inc.*, 580 F. App'x 907 (Fed. Cir. 2014).

C. Procedural History

IntegraSpec filed its complaint against Airlite in May 2012, while the *Reward Wall* action was pending. Specifically, IntegraSpec accused two separate lines of Airlite products of infringement: the Fox Block ICFs and the Fox Block 1440 ICFs. IntegraSpec alleged that the Fox Block ICFs infringed Claims 2 and 5 of the '933 Patent. *Decision on Appeal*, 2016 WL 5107131, at *1 n.3. It was undisputed that, like the Nudura ICFs found to be noninfringing in *Reward Wall*—the Fox Block ICFs have only one row of alternating projections and recesses on the top and bottom edges of each sidewall. *Id.*

IntegraSpec also alleged that the Fox Block 1440 ICFs infringed Claims 2, 4, 5, 19, and 27 of the '933 Patent. *Id.* IntegraSpec did not dispute that—like the Reward Wall iForm ICFs found noninfringing in *Reward Wall*—the Fox Blocks 1440 ICFs include projections that do not have the same measurable length, breadth, area, and volume, and that the differences are greater than 10%. *Id.*

Given the overlap of issues, Airlite filed a motion to stay this case pending the outcome of the second ex parte reexamination and the resolution of the *Reward Wall* litigation. The district court granted that motion in part, and stayed proceedings pending the outcome of the reexamination. Order, *Phil-Insul Corp. v. Airlite Plastics, Inc.*, No. 8:12-cv-151 (D. Neb. Oct. 18, 2012), ECF No. 35.

The parties thereafter agreed that the case should remain stayed pending resolution of the *Reward Wall* appeal.

After this court issued its decision in *Reward Wall*, the district court lifted the stay, and IntegraSpec moved for claim construction. Specifically, IntegraSpec asked the court to construe “adjacent” and “substantially the same dimension.” Airlite opposed that motion on collateral estoppel grounds, but nonetheless responded to IntegraSpec’s proposed constructions.

Airlite subsequently moved for summary judgment of noninfringement based on collateral estoppel. Therein, Airlite argued that IntegraSpec’s infringement claims against Airlite’s accused products are indistinguishable from the claims asserted against the defendants in *Reward Wall*. Airlite also argued that there are no material differences between the products found noninfringing in *Reward Wall* and its accused products. According to Airlite, because this court affirmed the claim construction of the “adjacent” and “dimension” limitations, those constructions are binding on IntegraSpec for collateral estoppel purposes.

In response, IntegraSpec argued that: (1) it did not have a full and fair opportunity to litigate the issues in *Reward Wall* because it now alleges infringement of Claim 2, rather than Claim 1; (2) the district court’s claim construction in *Reward Wall* was incorrect; and (3) “the defense of collateral estoppel is not available in this case because the claim construction was not essential to the court’s noninfringement rulings.” *Decision on Appeal*, 2016 WL 5107131, at *6. According to IntegraSpec, the district court’s claim construction in *Reward Wall* created an “irreconcilable conflict between Claims 1 and 2.” *Id.* at *7.

On March 2, 2016, the district court granted Airlite’s motion for summary judgment based on collateral estoppel. First, the court explained that the patent claims at

issue contain the same “adjacent” and “dimension” terms that were construed in *Reward Wall*. *Id.* at *9. “The construction of those terms was dispositive of the issue of non-infringement in that case.” *Id.* Although IntegraSpec alleges that Airlite infringes Claim 2, rather than Claim 1, and argues that Claim 2 was not considered in *Reward Wall*, it conceded to the district court that Claim 2 contains all of the limitations of the now-cancelled Claim 1. *Id.*

Next, the court found that all of the elements for collateral estoppel were satisfied for both the claim construction and noninfringement issues presented. Specifically, the court found that IntegraSpec had a “full and fair opportunity to litigate” the claim constructions in *Reward Wall* and that the court’s construction of those terms resulted in a finding of noninfringement. *Id.* The court further found that: (1) the infringement issues in this case are “essentially indistinguishable” from those in *Reward Wall*; and (2) the accused Airlite products have the same design as the products found noninfringing in *Reward Wall*. *Id.* at *9-10.

IntegraSpec timely appealed the district court’s final judgment to this court. We have jurisdiction under 28 U.S.C. § 1295(a)(1).

II. STANDARD OF REVIEW

We review a grant of summary judgment under the law of the regional circuit. *Grober v. Mako Prods., Inc.*, 686 F.3d 1335, 1344 (Fed. Cir. 2012). The Eighth Circuit reviews a grant of summary judgment de novo. *Wilson v. Spain*, 209 F.3d 713, 716 (8th Cir. 2000). Summary judgment is appropriate if “the movant shows that there is no genuine dispute as to any material fact and the movant is entitled to judgment as a matter of law.” Fed. R. Civ. P. 56(a).

III. DISCUSSION

Collateral estoppel “precludes a plaintiff from relitigating identical issues by merely ‘switching adversaries’” and prevents a plaintiff from “asserting a claim that the plaintiff had previously litigated and lost against another defendant.” *Parklane Hosiery Co. v. Shore*, 439 U.S. 322, 329 (1979) (citation omitted). Because the application of general collateral estoppel principles is not within the exclusive jurisdiction of this court, we apply the law of the circuit in which the district court sits. *Aspex Eyewear, Inc. v. Zenni Optical Inc.*, 713 F.3d 1377, 1380 (Fed. Cir. 2013).

In the Eighth Circuit, the application of collateral estoppel is a question of law reviewed de novo on appeal. *Robinette v. Jones*, 476 F.3d 585, 588 (8th Cir. 2007). Collateral estoppel requires five elements:

(1) the party sought to be precluded in the second suit must have been a party, or in privity with a party, to the original lawsuit; (2) the issue sought to be precluded must be the same as the issue involved in the prior action; (3) the issue sought to be precluded must have been actually litigated in the prior action; (4) the issue sought to be precluded must have been determined by a valid and final judgment; and (5) the determination in the prior action must have been essential to the prior judgment.

Id. at 589 (citation omitted).

Federal Circuit precedent applies, however, to aspects of the collateral estoppel analysis that are particular to patent law. *Aspex Eyewear*, 713 F.3d at 1380 (“[F]or any aspects that may have special or unique application to patent cases, Federal Circuit precedent is applicable.”). Under this court’s precedent, “an infringement claim in a second suit is the ‘same claim’ as in an earlier infringe-

ment suit if the accused products in the two suits are ‘essentially the same.’” *Roche Palo Alto LLC v. Apotex, Inc.*, 531 F.3d 1372, 1379 (Fed. Cir. 2008) (citation omitted). “Accused products are ‘essentially the same’ where the differences between them are merely colorable or unrelated to the limitations in the claim of the patent.” *Id.*

Applying this framework, the district court found each of the collateral estoppel criteria satisfied for the claim construction and the noninfringement issues presented in this case. With respect to claim construction, the court found that: (1) IntegraSpec was a party in *Reward Wall*; (2) the construction of the “adjacent” and “substantially the same dimension” claim terms were issues in the prior case; (3) construction of those terms was “actually litigated” in *Reward Wall*; (4) the claim constructions became final when we affirmed them on appeal; and (5) the claim constructions were essential to the noninfringement judgments in *Reward Wall*. *Decision on Appeal*, 2016 WL 5107131, at *9.

With respect to noninfringement, the court explained that the infringement issues IntegraSpec litigated in *Reward Wall* are “substantively the same” as those presented here. *Id.* Specifically, the court found that the noninfringement issues regarding the accused products in *Reward Wall* were fully and fairly litigated in that proceeding; those determinations were essential to the final judgment of noninfringement; and the judgment of noninfringement was final because it was not appealed. *Id.* In addition, the district court found that Airlite’s accused products do not infringe the ’933 Patent “for the same reasons stated in connection with the accused Nudura ICFs and Reward Wall [iForm] ICFs in *Reward Wall*.” *Id.* at *10. In reaching this conclusion, the court noted that the accused products in this case have the same design as the products found not to infringe in *Reward Wall*. *Id.*

IntegraSpec submits that two of the collateral estoppel requirements are at issue on appeal: whether there was a valid and final judgment and whether the determination in the prior action was “essential” to the prior judgment. Appellant’s Reply 5-6. In particular, IntegraSpec argues that the district court erred when it: (1) gave collateral estoppel effect to a Rule 36 judgment; (2) relied on the oral argument transcript from the *Reward Wall* appeal; and (3) failed to construe Claim 2. We address each argument in turn.

A. Rule 36 and Collateral Estoppel

IntegraSpec’s primary argument on appeal is that a Rule 36 judgment can never serve as a basis for collateral estoppel. We disagree.

Federal Circuit Rule 36 provides that:

The court may enter a judgment of affirmance without opinion, citing this rule, when it determines that any of the following conditions exist and an opinion would have no precedential value:

- (a) the judgment, decision, or order of the trial court appealed from is based on findings that are not clearly erroneous;
- (b) the evidence supporting the jury’s verdict is sufficient;
- (c) the record supports summary judgment, directed verdict, or judgment on the pleadings;
- (d) the decision of an administrative agency warrants affirmance under the standard of review in the statute authorizing the petition for review; or
- (e) a judgment or decision has been entered without an error of law.

Fed. Cir. R. 36. As we have explained on several occasions, “[a]ppeals whose judgments are entered under Rule

36 receive the full consideration of the court, and are no less carefully decided than the cases in which we issue full opinions. The Rule permits the court to dispense with issuing an opinion that would have no precedential value, when the circumstances of the Rule exist.” *U.S. Surgical Corp. v. Ethicon, Inc.*, 103 F.3d 1554, 1556 (Fed. Cir. 1997).

A Rule 36 summary affirmance is a valid and final judgment of this court. *See Taylor v. McKeithen*, 407 U.S. 191, 194 n.4 (1972) (“We, of course, agree that the courts of appeals should have wide latitude in their decisions of whether or how to write opinions. That is especially true with respect to summary affirmances.”). We have explained that, because there is no opinion, “a Rule 36 judgment simply confirms that the trial court entered the correct judgment.” *Rates Tech., Inc. v. Mediatrice Telecom, Inc.*, 688 F.3d 742, 750 (Fed. Cir. 2012). “It does not endorse or reject any specific part of the trial court’s reasoning.” *Id.* That said, we have also expressly recognized that a Rule 36 disposition can be used “in support of a claim of ‘claim preclusion, issue preclusion, judicial estoppel, law of the case, and the like.’” *Id.* (quoting Fed. Cir. R. 32.1(c)).

The Supreme Court likewise has recognized that a summary affirmance has binding precedential effect, but it “extends no further than ‘the precise issues presented and necessarily decided by those actions.’” *Anderson v. Celebrezze*, 460 U.S. 780, 786 n.5 (1983) (“A summary disposition affirms only the judgment of the court below, and no more may be read into our action than was essential to sustain that judgment.”). As such, the Court has said that summary affirmances only “prevent lower courts from coming to opposite conclusions on the precise issues presented and necessarily decided by those actions.” *Mandel v. Bradley*, 432 U.S. 173, 176 (1977). Consistent with this approach, our internal operating procedures provide that “Rule 36 judgments shall not be employed as

binding precedent by this court, except in relation to a claim of res judicata, collateral estoppel, or law of the case[.]” Fed. Cir. Internal Operating Procedure No. 9 ¶ 8 (Nov. 14, 2008). Accordingly, it is clear that a Rule 36 affirmance is a binding judgment for collateral estoppel purposes.

IntegraSpec argues that our decision in *TecSec, Inc. v. International Business Machines Corp.*, 731 F.3d 1336 (Fed. Cir. 2013) created a new rule: that a Rule 36 summary affirmance cannot have preclusive effect. We disagree. Indeed, a careful reading of that decision reveals that it supports application of estoppel in this case.

In *TecSec*, TecSec accused IBM and several other defendants of infringement. The district court severed TecSec’s claims against IBM and stayed proceedings against the other defendants. *Id.* at 1340. IBM filed a motion for summary judgment of noninfringement. The district court granted IBM’s motion on two separate and independent grounds. Specifically, the court found that: (1) TecSec failed to present sufficient evidence of direct and indirect infringement; and (2) TecSec failed to show that IBM’s software met various claim limitations, as construed. *Id.* at 1342. TecSec appealed the district court’s judgment to this court, challenging both of the court’s determinations. After oral argument, we affirmed the district court’s judgment without opinion pursuant to Rule 36. *TecSec, Inc. v. IBM*, 466 F. App’x 882 (Fed. Cir. 2012).

On remand, proceedings against the other defendants remained, and TecSec stipulated that it could not prove infringement under the claim construction adopted in the IBM proceedings. Based on that stipulation, the district court entered judgment of noninfringement in favor of the defendants. TecSec appealed that judgment to this court. On appeal, the defendants argued that, under the mandate rule and collateral estoppel, the Rule 36 affirmance

in the IBM appeal precluded TecSec from reasserting its claim construction arguments.¹ *TecSec*, 731 F.3d at 1341. TecSec responded that collateral estoppel did not apply because the district court’s claim constructions were not “necessary to the final judgment, which rested on multiple, independent grounds.” *Id.* at 1343. Because this court could have affirmed on either ground, TecSec argued that claim construction was not actually determined in the IBM appeal and was therefore not necessary to the Rule 36 affirmance.

We agreed with TecSec that collateral estoppel did not apply. Although the district court stated that its claim constructions were “strictly necessary” to resolving the parties’ summary judgment motions, we found that the court’s judgment based on TecSec’s failure of proof was independent of the court’s construction. *Id.* at 1344. Because claim construction was “neither actually determined by nor critical and necessary to our summary affirmance in the IBM appeal,” we found that collateral estoppel did not preclude TecSec’s challenge. *Id.*

In *TecSec*, we reiterated that “Rule 36 judgments only affirm the judgment of the lower tribunal. [A] Rule 36 judgment simply confirms that the trial court entered the correct judgment. It does not endorse or reject any specific part of the trial court’s reasoning.” *Id.* at 1343 (quoting *Rates Tech.*, 688 F.3d at 750). Citing this language, IntegraSpec argues that a Rule 36 affirmance can never give rise to collateral estoppel. But we expressly rejected IntegraSpec’s proposed rule in *TecSec*. Specifically, we made clear that “[h]ad claim construction been the only issue in the *IBM* appeal, and had that claim construction been essential to sustaining the judgment of noninfringe-

¹ Although the mandate rule was at issue in *TecSec*, it is not at issue in this appeal, and is therefore not discussed herein.

ment, the preclusive effect of our Rule 36 judgment would have been undeniable.” *Id.*

Despite IntegraSpec’s arguments to the contrary, *TecSec* did not create a categorical ban against asserting a Rule 36 judgment for collateral estoppel purposes. Instead, it stands for the proposition that collateral estoppel cannot apply where the appellate court affirmed, without explanation, the judgment of a trial court that “determined two issues, either of which could independently support the result,” because it is not known which issue was “necessary” to the final appellate judgment.² *Id.* at

² We recognize that circuits are split on the related but different question of whether alternative holdings that are each independently sufficient to support a judgment can be given preclusive effect. See *Jean Alexander Cosmetics, Inc. v. L’Oreal USA, Inc.*, 458 F.3d 244, 251-52 (3d Cir. 2006) (collecting cases and noting “no consensus among the courts of appeals”). The Courts of Appeals for the Second, Third, Ninth, and Eleventh Circuits generally give preclusive effect to independent alternative holdings. See *Gelb v. Royal Globe Ins. Co.*, 798 F.2d 38, 45 (2d Cir. 1986) (“The general rule in this Circuit is that ‘if a court decides a case on two grounds, each is a good estoppel.’” (quoting *Irving Nat’l Bank v. Law*, 10 F.2d 721, 724 (2d Cir. 1926))); *Jean Alexander Cosmetics*, 458 F.3d at 255 (“Thus, we will follow the traditional view that independently sufficient alternative findings should be given preclusive effect.”); *In re Westgate-Cal. Corp.*, 642 F.2d 1174, 1176-77 (9th Cir. 1981) (following the “established rule” that estoppel applies even where a court “rests its judgment alternatively upon two or more grounds”); *Deweese v. Palm Beach*, 688 F.2d 731, 734 (11th Cir. 1982) (“Normally, each alternative basis would form an independent ground for collateral estoppel. . . . In this case, however, the existence of alternative grounds makes

1343-44. *TecSec* is therefore consistent with the principle that, for estoppel to apply, there must be no uncertainty as to whether the precise issue was raised and determined in the prior suit. *De Sollar v. Hanscome*, 158 U.S. 216, 221 (1895) (“[I]t is of the essence of estoppel by judgment that it is certain that the precise fact was determined by the former judgment.”).

Unlike the situation in *TecSec*, here it is clear that the prior panel actually and necessarily adopted the district court’s claim constructions when it affirmed the judgments in *Reward Wall*. In the *Reward Wall* appeal, IntegraSpec raised only two issues of claim construction: (1) the “adjacent” limitation; and (2) the “substantially the same dimension” limitation. *Decision on Appeal*, 2016

the application of offensive collateral estoppel problematic.”).

The Fourth, Seventh, and Tenth Circuits have declined to give independently sufficient alternative holdings preclusive effect. See *In re Microsoft Corp. Antitrust Litig.*, 355 F.3d 322, 328 (4th Cir. 2004) (“if a judgment in the prior case is supported by either of two findings, neither finding can be found essential to the judgment”); *Peabody Coal Co. v. Spese*, 117 F.3d 1001, 1008 (7th Cir. 1997) (en banc) (“Holdings in the alternative, either of which would independently be sufficient to support a result, are not conclusive in subsequent litigation with respect to either issue standing alone.”); *Turney v. O’Toole*, 898 F.2d 1470, 1472 n.1 (10th Cir. 1990) (noting that, where a petition for writ gave two reasons for relief, either of which would be sufficient, and the order granting the writ did not explain its reasoning, the writ had no preclusive effect). Because the *Reward Wall* proceedings did not involve independent alternative holdings, either below or on appeal, we need not address this split in authority.

WL 5107131 at *5. The former construction supported the district court's November 26, 2012 noninfringement judgment as to the accused Nudura ICFs, and the latter supported the court's September 5, 2013 noninfringement judgment as to the accused Reward Wall iForm ICFs. Neither of the claim constructions on appeal could have independently supported both noninfringement judgments. Therefore, our Rule 36 affirmance in *Reward Wall* necessarily meant that we found no error in either of the district court's claim constructions.

As the district court explained, the claim constructions affirmed on appeal in *Reward Wall* were essential to the noninfringement determinations therein. *Id.* at *9. IntegraSpec did not raise on appeal issues adjudicated in the district court's noninfringement decisions. "An issue that falls within the scope of the judgment appealed from but is not raised by the appellant in its opening brief on appeal is necessarily waived. Unless remanded by this court, all issues within the scope of the appealed judgment are deemed incorporated within the mandate and thus are precluded from further adjudication." *Engel Indus., Inc. v. Lockformer Co.*, 166 F.3d 1379, 1383 (Fed. Cir. 1999) (citing *United States v. Russ*, 861 F.2d 184, 185 (8th Cir. 1988)). Accordingly, the noninfringement determinations in *Reward Wall* are final for collateral estoppel purposes by virtue of IntegraSpec's failure to appeal them.

Although the district court in this case blended its analysis of collateral estoppel as to the claim construction and noninfringement issues, we find no error in the court's ultimate conclusion as to either issue. First, we agree with the district court that the claim constructions from *Reward Wall* are entitled to preclusive effect. The court correctly concluded that IntegraSpec was a party in *Reward Wall*, the "adjacent" and "substantially the same dimension" claim terms were construed in *Reward Wall*, construction of those terms was "actually litigated" in that

case, the claim constructions became final when we affirmed them on appeal, and the claim constructions were essential to the noninfringement judgments. *Decision on Appeal*, 2016 WL 5107131, at *9. Because the record reveals that IntegraSpec had a full and fair opportunity to litigate the meaning of the terms “adjacent” and “dimension”—the same terms at issue here—it is bound by those constructions.

The district court also found that IntegraSpec’s infringement claims in this case are the same as the infringement claims it litigated and lost in *Reward Wall*. In reaching this conclusion, the district court found that Airlite’s accused Fox Blocks ICFs have the same design of only one row of projections and recesses on the top and bottom edges of each sidewall as the Nudura ICFs that were found not to infringe the “adjacent” limitation in *Reward Wall*. *Id.* Likewise, the court concluded that the accused Fox 1440 ICFs in this case have the same design of projections that differ in volume by greater than 10% as the Reward Wall ICFs that were adjudicated in *Reward Wall* to not infringe the “substantially same dimension” limitation of Claim 1. *Id.* at *10. IntegraSpec does not challenge these determinations on appeal. Nor could it, given that counsel for IntegraSpec conceded during argument to the district court that there was “no substantial difference” between the Nudura ICFs found noninfringing in *Reward Wall* and the Fox Blocks ICFs accused of infringement here. Transcript of Proceedings at 75:5-76:12, *Phil-Insul Corp. v. Airlite Plastics, Co.*, No. 8:12-cv-151 (D. Neb. July 31, 2015), ECF. No. 73.

The district court noted that IntegraSpec did not propound “any argument or evidence on the substantive issue of noninfringement.” *Decision on Appeal*, 2016 WL 5107131, at *10 n.13. On appeal, IntegraSpec concedes that the determination of no literal infringement in *Reward Wall* was based on the court’s claim construction, but maintains that its claim for infringement under the

doctrine of equivalents was not. It is well established, however, that an infringement analysis is a two-step process. The court must: (1) determine the scope and meaning of the patent claims asserted; and (2) compare the properly construed claims to the allegedly infringing device. *Cybor Corp. v. FAS Techs., Inc.*, 138 F.3d 1448, 1454 (Fed. Cir. 1998) (en banc). IntegraSpec fails to explain how the determinations of noninfringement under the doctrine of equivalents in *Reward Wall* were allegedly made without reference to claim construction. Accordingly, we find IntegraSpec's arguments with respect to the doctrine of equivalents unpersuasive.

On this record, and given IntegraSpec's concession that the accused products in this case are substantially the same as those at issue in *Reward Wall*, we find no error in the district court's conclusion that Airlite's accused products do not infringe the '933 Patent.

B. The *Reward Wall* Appellate Record

Next, IntegraSpec argues that the district court did not understand the appellate record in *Reward Wall* and misrepresented the oral argument transcript. According to IntegraSpec, the district court here relied almost entirely on what was said about claim construction at the oral hearing, but failed to recognize that two judges on the panel "doubted that the district court construction made sense." Appellant Br. at 22. We disagree.

As noted, the district court correctly determined that the only issues IntegraSpec raised on appeal in *Reward Wall* were the construction of the "adjacent" and "substantially the same dimension" limitations. The court cited IntegraSpec's opening brief on appeal in *Reward Wall* in support of this determination. *Decision on Appeal*, 2016 WL 5107131, at *5. The court also noted that the audio recording of the oral argument in *Reward Wall* confirmed that IntegraSpec did not challenge the noninfringement determinations in that appeal. *Id.* at *5 n.8.

The district court did not err in citing these sources to confirm the scope of what was at issue in *Reward Wall*. That the panel of judges in the *Reward Wall* appeal appeared to challenge the appellee during oral argument does not establish that they doubted the district court's claim construction. The fact remains that the panel issued a Rule 36 affirmance. Accordingly, IntegraSpec's interpretation of the oral argument in *Reward Wall* is irrelevant.

C. Claim Construction of Claim 2

IntegraSpec also argues that Claim 2 must be construed in this case because it was not at issue in *Reward Wall*. According to IntegraSpec, the district court in *Reward Wall* only construed Claims 1 and 19, and its construction of the term “adjacent” in Claim 1 created an irreconcilable conflict with Claim 2.

Airlite responds that IntegraSpec asserted infringement of Claim 2—not Claim 1—against the Nudura ICFs in *Reward Wall*. Airlite also argues that the disputed claim terms in this case—“adjacent” and “substantially the same dimension”—were at issue in *Reward Wall*, and the court considered and rejected IntegraSpec's claim construction arguments in that case.

We agree with Airlite. In *Reward Wall*, the parties jointly requested early claim construction of certain claim terms found in both Claim 1 and Claim 19 of the '933 Patent. *Decision on Appeal*, 2016 WL 5107131, at *3. Because the parties selected the claims and the claim terms to be construed, IntegraSpec's suggestion that the district court overlooked and failed to construe other claims is without merit. As the district court explained, the patent claims at issue here contain the same “adjacent” and “dimension” terms that the court construed in *Reward Wall*. *Id.* at *9. Although *Reward Wall* involved Claims 1 and 19, IntegraSpec conceded to the district court in this case that Claim 2 contains all of the same

limitations of Claim 1, which was cancelled during reexamination. *Id.* The court found that those claim terms were dispositive of the issue of noninfringement in *Reward Wall*.

At oral argument, counsel for IntegraSpec argued that, although the same terms appear in Claims 1 and 2, those terms can be construed differently between the two claims. Oral Argument at 10:52-11:00, available at <http://oralarguments.cafc.uscourts.gov/default.aspx?fl=2016-1982.mp3> (“So you are saying that the exact same language could be construed differently? In the context of a different claim, yes.”). It is well-established, however, that claim terms are to be construed consistently throughout a patent. *Rexnord Corp. v. Laitram Corp.*, 274 F.3d 1336, 1342 (Fed. Cir. 2001) (“Furthermore, a claim term should be construed consistently with its appearance in other places in the same claim or in other claims of the same patent.”).

In any event, the district court considered and rejected IntegraSpec’s claim construction arguments in *Reward Wall*, and we affirmed the court’s constructions on appeal. We decline IntegraSpec’s request to reconstrue those terms now. IntegraSpec’s arguments were either made or could have been made in *Reward Wall*, and they cannot preclude the application of estoppel in this case.

IV. CONCLUSION

For the foregoing reasons, we affirm the district court’s judgment of noninfringement.

AFFIRMED